



Continuous Flow Attachment

DESCRIPTION: The stainless steel, in-line continuous flow cell uniformly processes low-viscosity solutions at rates up to 10 GPH (38 LPH). It can be used to emulsify, disperse, and homogenize by pumping a solution through a zone of intense ultrasonic activity. The degree of processing is controlled by varying the amplitude of the ultrasonic horn and the flow rate. Some solutions may require recirculating until the desired results are obtained. The continuous flow attachment incorporates a cooling jacket through which a suitable cooling liquid can be circulated to retard heat build-up during extended operation. The attachment

may also be sealed in a closed system to assure sterile conditions and inhibit contamination when working with infectious materials.

Overall Dimensions:

Length - 5"

Diameter - 3.8" (includes ports)

TYPICAL APPLICATIONS

- Production of vaccines and antigens
- Emulsification of immiscible liquids (with or w/o surfactants)
- Removal of cell walls
- Dispersing metal oxides in solvents

USAGE PROCEDURES: To use your Branson continuous flow attachment:

1. Gently screw the clean continuous flow attachment onto the threaded disruptor horn (compress neoprene “O” rings to engage threads) until horn tip touches the orifice disc. Caution: Horn tip can damage the orifice disc if components are screwed too tightly together.

2. When horn tip is in contact with the disc, unscrew one complete turn. Each complete revolution increases or decreases the distance of the horn tip from the orifice by 0.30” (0.762 mm). As a result, flow rates can be controlled and reset when needed.

The smaller the distance between the tip and the disc, the slower the flow rate and the more intense the disruption, and vice versa.

3. Clamp the continuous flow attachment to a suitable stand and use appropriate input/output connectors (with 0.25” ID [6.35 mm] hose), as shown in Figures 1, 2, and 3.

4. A gravity method or pump can be used to drive the solution through the continuous flow attachment. Before beginning flow, set the timer to hold, the duty cycle to constant, and select the desired power setting.

Turn on the Sonifier unit and immediately begin flow. You may want to discard first part of solution if it is not fully processed. If using a gravity flow method, be sure to turn the Sonifier off as soon as flow has stopped. *To prevent overheating, always avoid operating the Sonifier cell disruptor for more than a few seconds without liquid moving through the attachment.*

TROUBLESHOOTING:

Problem	Solution
Leaking at inlet/ outlet	Replace 0.312” ID ports (7.65 mm) O-rings.
Air or foaming at horn interface	Replace 1.375” ID (34.52 mm) O-ring.
No or reduced flow rate	Ensure there is a space between horn face and orifice disc. Check for build-up of sludge or solids between orifice disc and ase section, Part A.
Foaming of sample material	Check to ensure that solution level is above horn tip. Increase flow pressure.

CLEANING AND HANDLING:

The continuous flow attachment requires careful handling, especially the ceramic disc. Replacement discs can be ordered from Branson. To disassemble for cleaning or sterilization, use the small open wrench supplied to unscrew the bottom or base (A) from the body (B), exposing the neoprene (rubber) washer and orifice disc. Solution ports are held in place by “O” rings and can be easily removed by a slight twisting and pulling action. Cooling ports are not removable. To clean prior to autoclaving, rinsing and immersion in a Branson ultrasonic bench top cleaner is recommended. When reassembling, make sure that base section (A) is screwed onto the body (B) hand tight.

SIDE VIEW

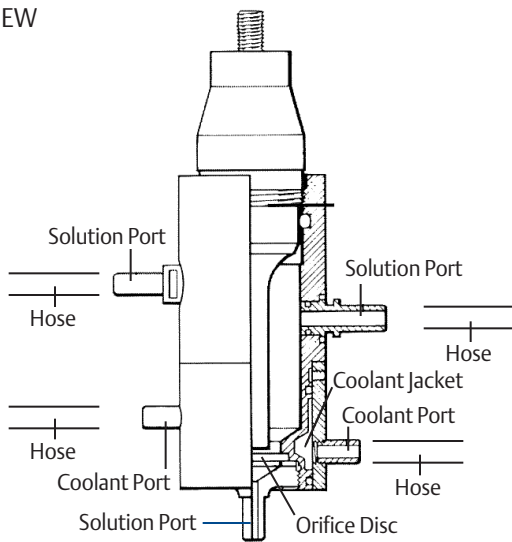

BOTTOM VIEW

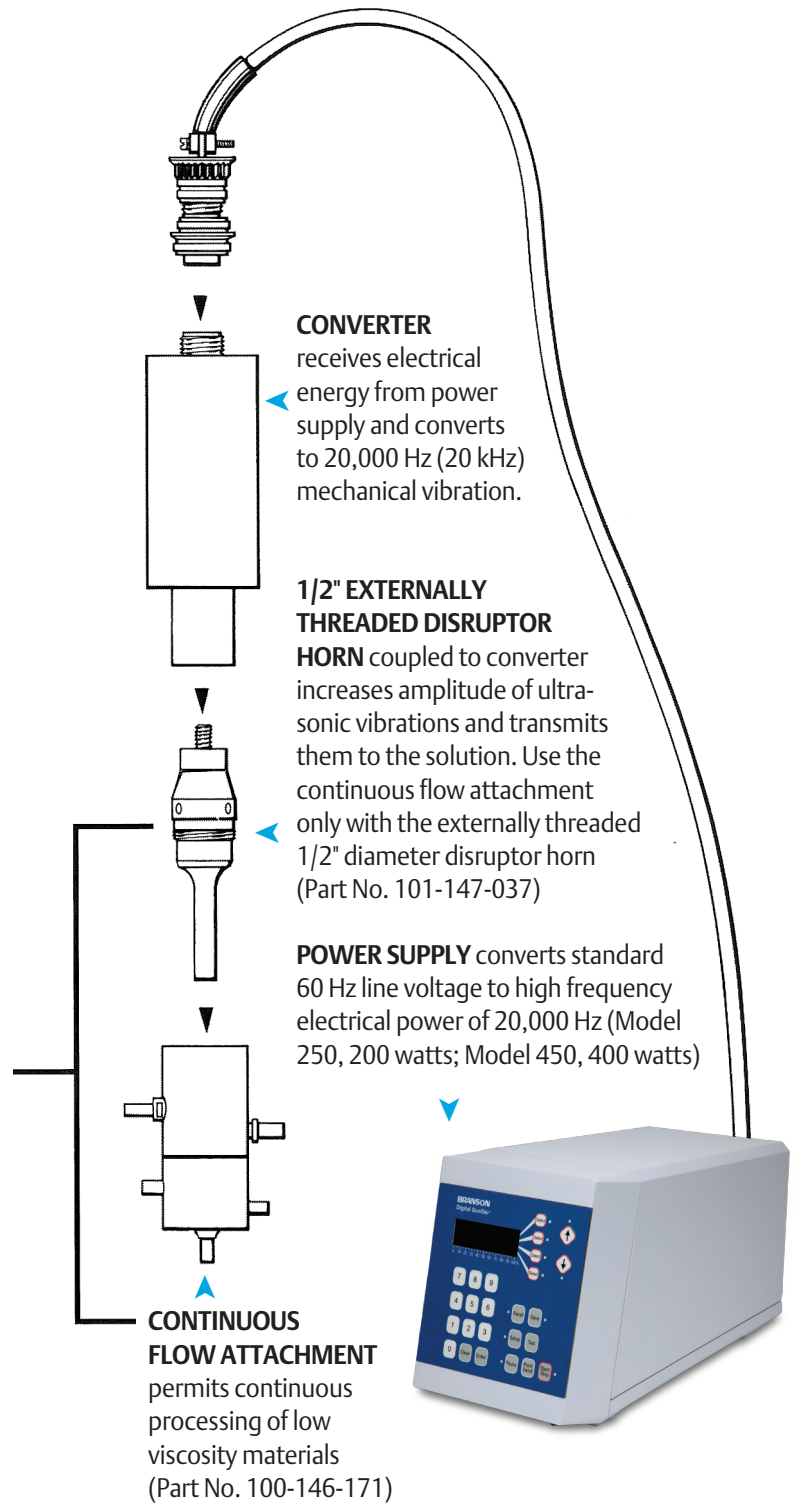
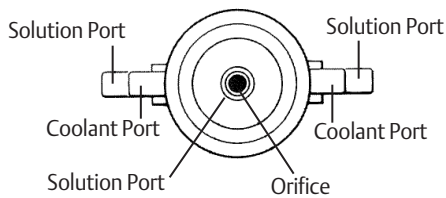

Sonifier Cell Disruptor

REPLACEMENT PARTS:

Neoprene accessories:

- **Washer for orifice disc**
(0.75" ID [19.05 mm])
Part No. 100-114-027
- **Solution port "O" rings**
(0.312" ID [7.65 mm])
Part No. 200-087-024
- **Sealing horn "O" ring**
(1.375" ID [34.52 mm])
Part No. 200-087-059
- **Disc Orifice 1/8"**
(3.18 mm) dia.
Part No. 100-036-010
Max. pressure 50 PSI (3.5 kg/sq.cm).
Max. flow rate 10 GPH (38 LPH)

For industrial applications, continuous flow attachments are available which enable the processing of larger volumes. These attachments require a 1,000-watt Sonifier unit and can accommodate 1" or 1-1/2" diameter horns. For detailed information about our industrial applications equipment, see the ULTRASONIC LIQUID PROCESSING technical sheet.

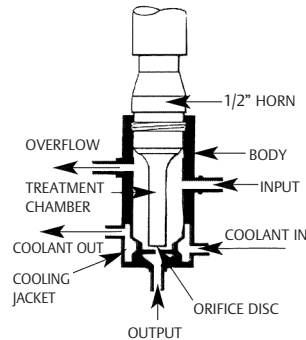

Figure 1

EMULSION, DISPERSION, AND HOMOGENIZING:

Solutions normally enter at the low side port and are processed beneath the horn face before exiting through the orifice at the bottom. An overflow port is provided, as well as connectors for circulating coolant. Solution may be fed to the attachment by either gravity feed or by use of a circulating pump (max. 5 PSI).

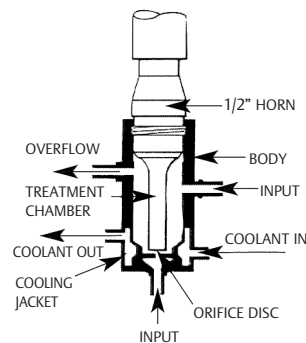

Figure 2

CELL DISRUPTION: For cell disruption, it is advisable to reverse the flow of the solution, pumping it through the bottom opening, past the horn tip toward the low side port. Note: Because of limited ultrasonic exposure time, the attachment is not recommended for disruption of difficult cells such as strep or yeast.

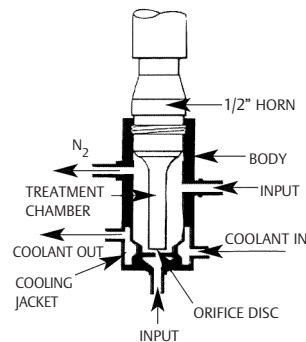

Figure 3

FOAM CONTROL: To minimize foaming, use the reverse flow method. This will minimize foam build-up in the chamber, which, if allowed to accumulate, will result in a reduction in the transmission of ultrasonic energy into the solution. Introducing N₂ through the high side port will prevent peroxide formation, which can injure sensitive biological components.

BRANSON

Branson Ultrasonics Corporation
41 Eagle Road, Danbury, CT 06813-1961
(203) 796-0400 • Fax: (203) 796-9838
www.bransonultrasonics.com
e-mail: info@bransonultrasonics.com